

NO	DTAE	CODE	NOTE	DRAW	APPRO
△					
△					
△					

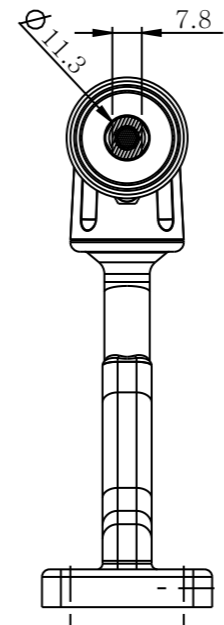

SECTION A-A

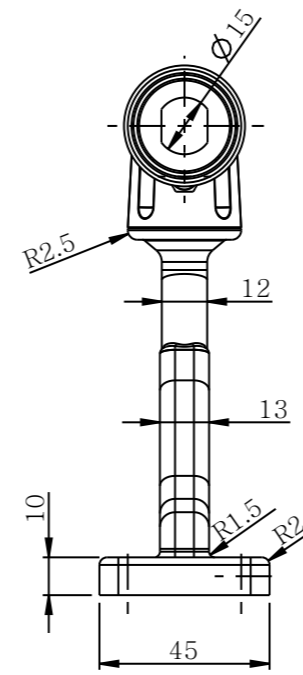
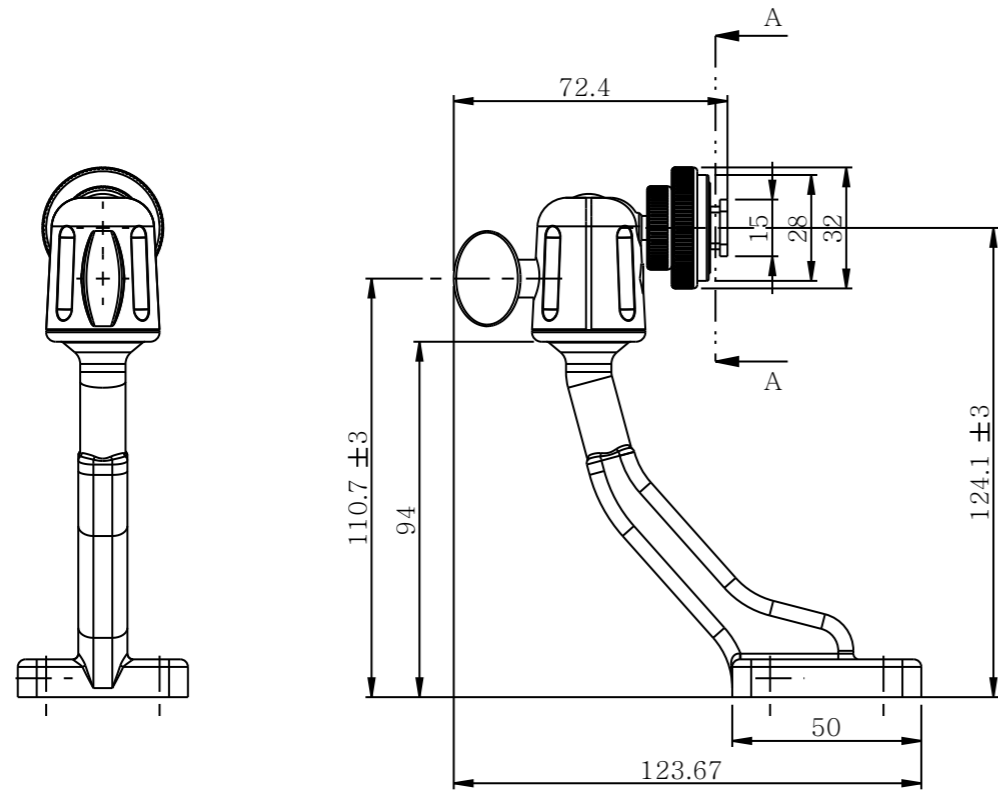
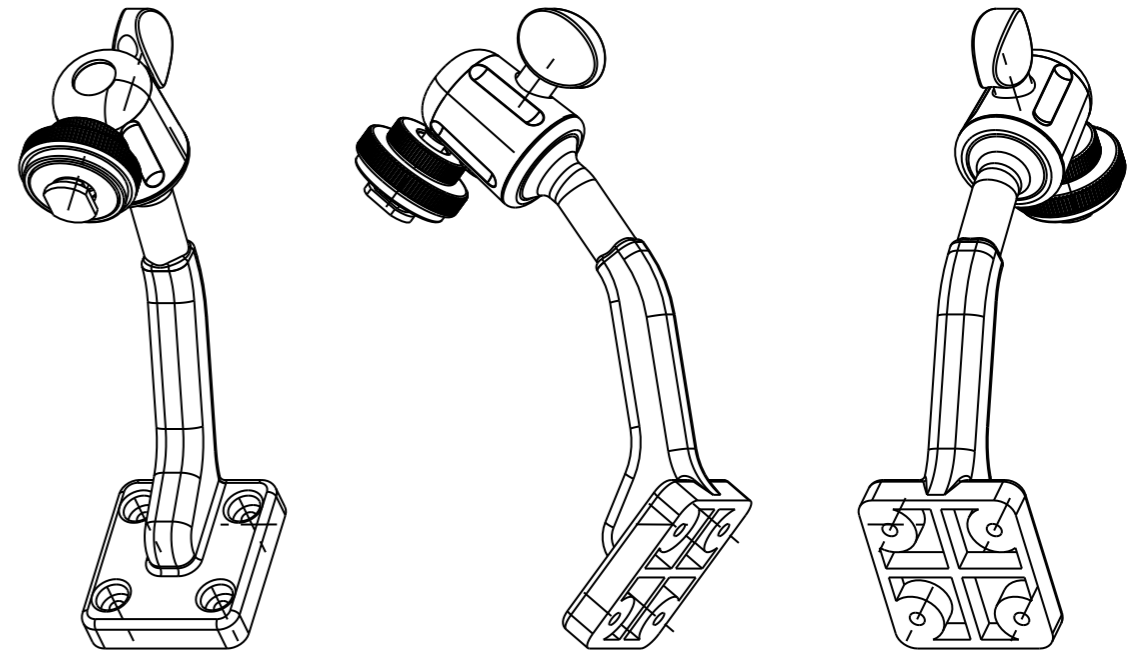
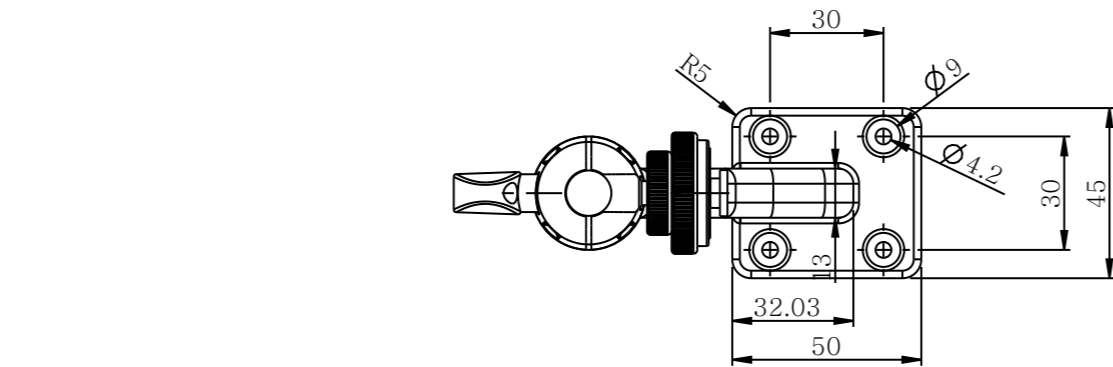
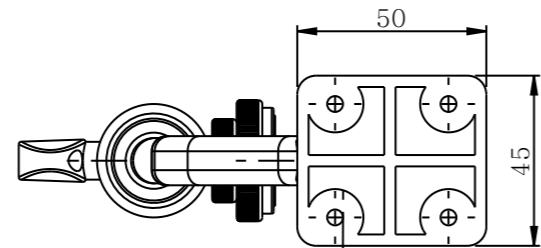

150 -	±0.35	±0.50	±0.80	3						
80 - 150	±0.25	±0.35	±0.50	2						
50 - 80	±0.20	±0.25	±0.40	1					1	
30 - 50	±0.15	±0.20	±0.35		NO	CODE	MATERIAL	TREATMENT	Q'TY	REMARK
18 - 30	±0.10	±0.15	±0.30		DRAW	CHECK	APPRO		DWG NO.	
6 - 18	±0.08	±0.10	±0.20		B.Y.CHOI	W.J.NAM			DATE 2009.07.06	MODEL NAME
- 6	±0.05	±0.08	±0.15						SCALE 1:2	MONITOR
Division	A	B	C						UNIT mm	
TOLERANCE STEP (A)										
ANGULAR ±0.5°										
										CL-9S (Short Type)

A | B | C | D | E | F | G | H